

Freesmaten in bladen:

- Ingelegd rvs/blank poedercoating
- Tafelblad doorvoer/oplegrand 235X63XR8

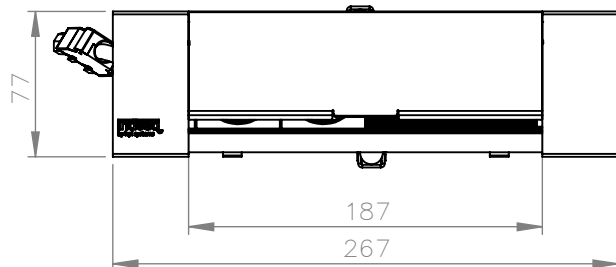
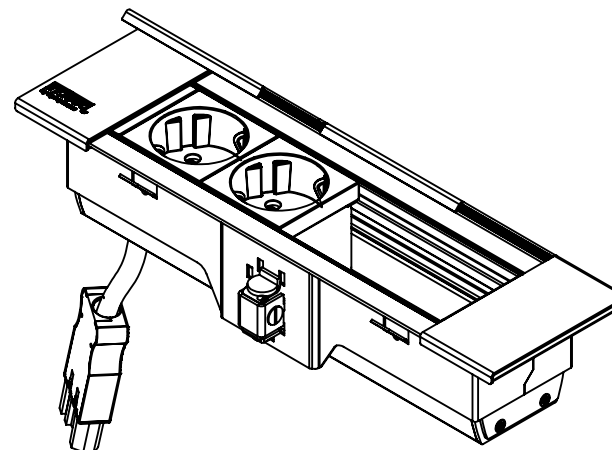
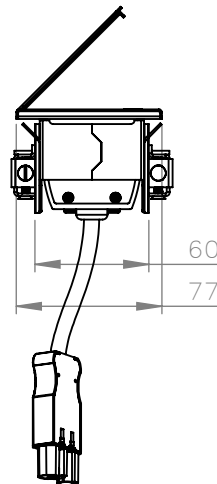
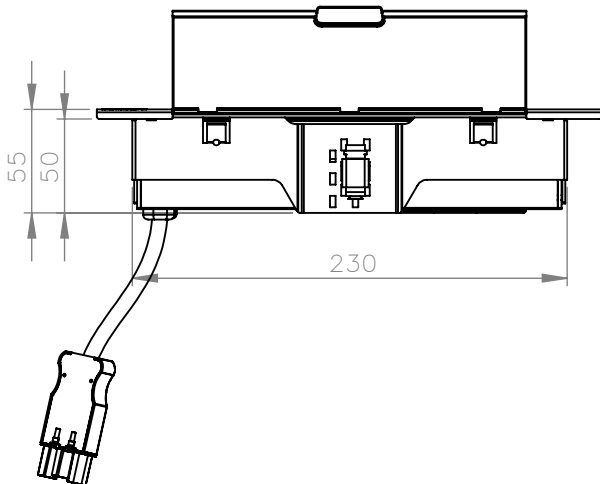

Alle maten in millimeters Alg. maat tol. ± 0,25 Alg. hoek tol. ± 0,25° Gereedschap			Tekening nummer <h1 style="margin: 0;">408.0032</h1>		Omschrijving, project Bureau-unit inbouw 4v "Hertz+"	
			Projectinformatie Indesq by HPL systems		Opmerking 2wcd, 2 M45, kabelaan sluiting 3-polig	
Getek.	Datum	Revisie	DO NOT SCALE DRAWING		<b>HURKMANS PLATWERK BV</b>	
BR	12-3-2015	21-4-2016	Materiaal, nabehandeling Material <not specified>			
			Gewicht in gram: 1104.7		Ontwerp en copyright Hurkmans Plaatwerk BV niets uit deze tekening mag zonder schriftelijke toestemming worden vermenigvuldigd of gebruikt door derden	
			Schaal: 1:4		Pagina 1 van 2	

Geschikt voor tafelbladen tot 37,5mm

A4

21-4-2016